

Amphenol Aerospace

CF-020400-027

Thermal Analysis

January 23, 2020

Ceferino Sanchez, Arjan Kole
Electronic Cooling Solutions Inc.

Contents

Objectives	<u>3</u>
Approach	<u>4</u>
Thermal Model Setup Details	<u>5 - 12</u>
Overview	
Thermal Data	
Thermal Analysis	<u>13 - 25</u>
Results Summary	
Plots	
Recommendations	

Objectives

1. To determine that the critical components on the CF-170200-233 board are within their thermal limits:
 - a) -30°C at 10,000 feet
 - b) 23°C at sea level
 - c) 50°C at sea level

At the three different power levels:

 - a) Sandia Config. – Total Power of 37.93W
 - b) 10G Op. - Total Power of 61.12W
 - c) Worst-case – Total Power of 87.91W
2. To determine the margins for critical components if the environment exceeds the maximum and minimum specified temperatures.

Approach

1. This analysis was done using FloTHERM XT V3.3 CFD software
2. The model was evaluated with an approach airflow of 600 LFM and with the assumption that the approach air temperature matches the ambient temperature of the environment.
3. The thermal model was created from the 3u_convection_assy_asm_011620.zip simplified for thermal analysis.
4. The board was modeled based on the ODB++ file.
5. Adjacent cards of 75W and 25W were assumed to have similar geometries as the Amphenol board but with the components suppressed or inactive. The 75W and 25W were applied as thermal planar sources on the base of the primary frames.
6. The thermal gap pads on the primary frame coupled to the critical components are SilPad2000 with $k = 3.5 \text{ W/m-K}$ at 0.015" thick

Thermal Model Setup

Thermal Model Setup –Overview: Board

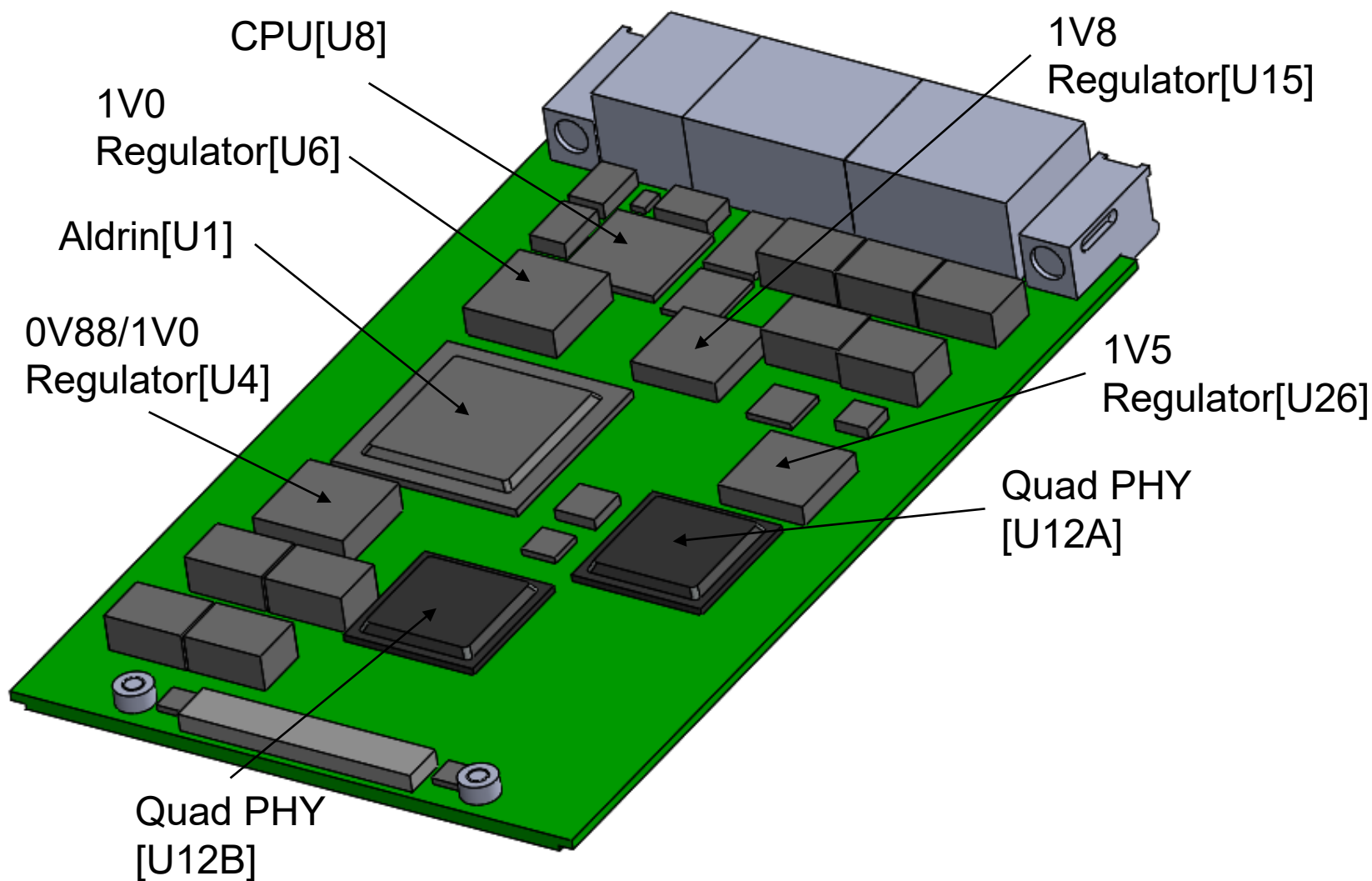

Thermal Model Setup –Overview: Thermal Gap Pads

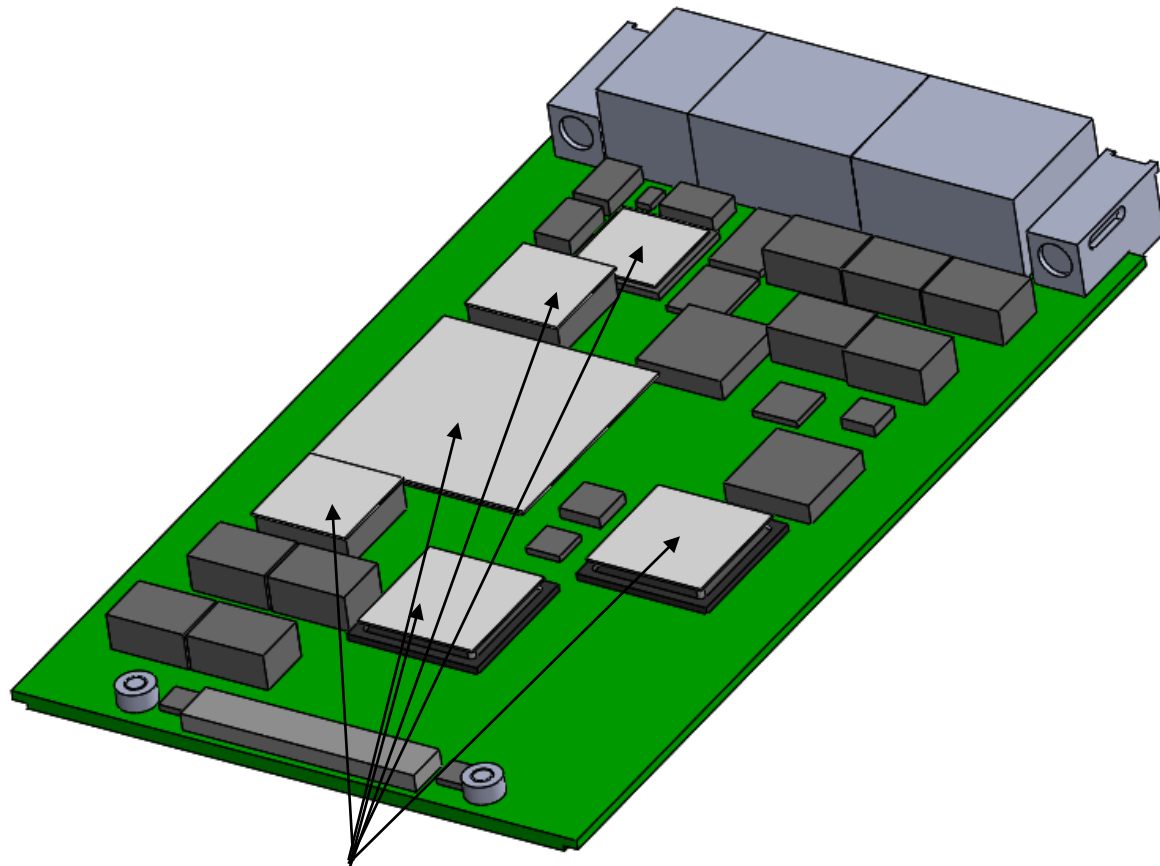

Thermal Gap Pads
(SilPad2000)
[0.015" thick; $k = 3.5 \text{ W/m-K}$]

Thermal Model Setup –Overview: Frame

Primary Frame
[Al6061-T6]

Fin thickness: 1.397mm
Fin gap: 2.54mm
Fin height: 6.985 mm
Number of fins: 35

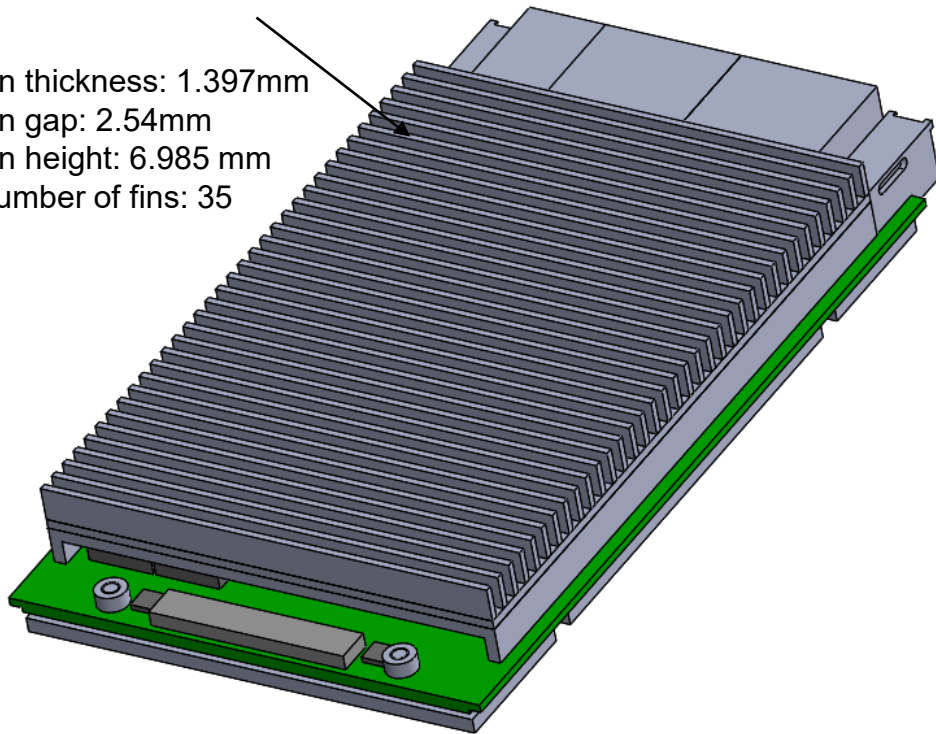

Secondary Frame
[Al6061-T6]

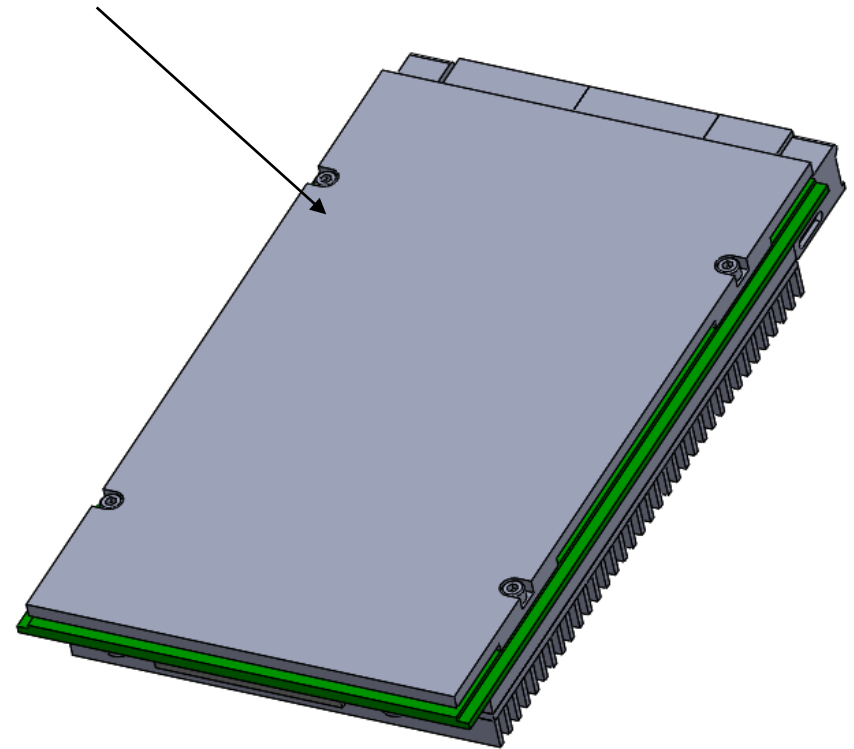

Screws/washers (in frame assembly): [300 Series Stainless Steel]

Thermal Model Setup –Overview: Adjacent Boards

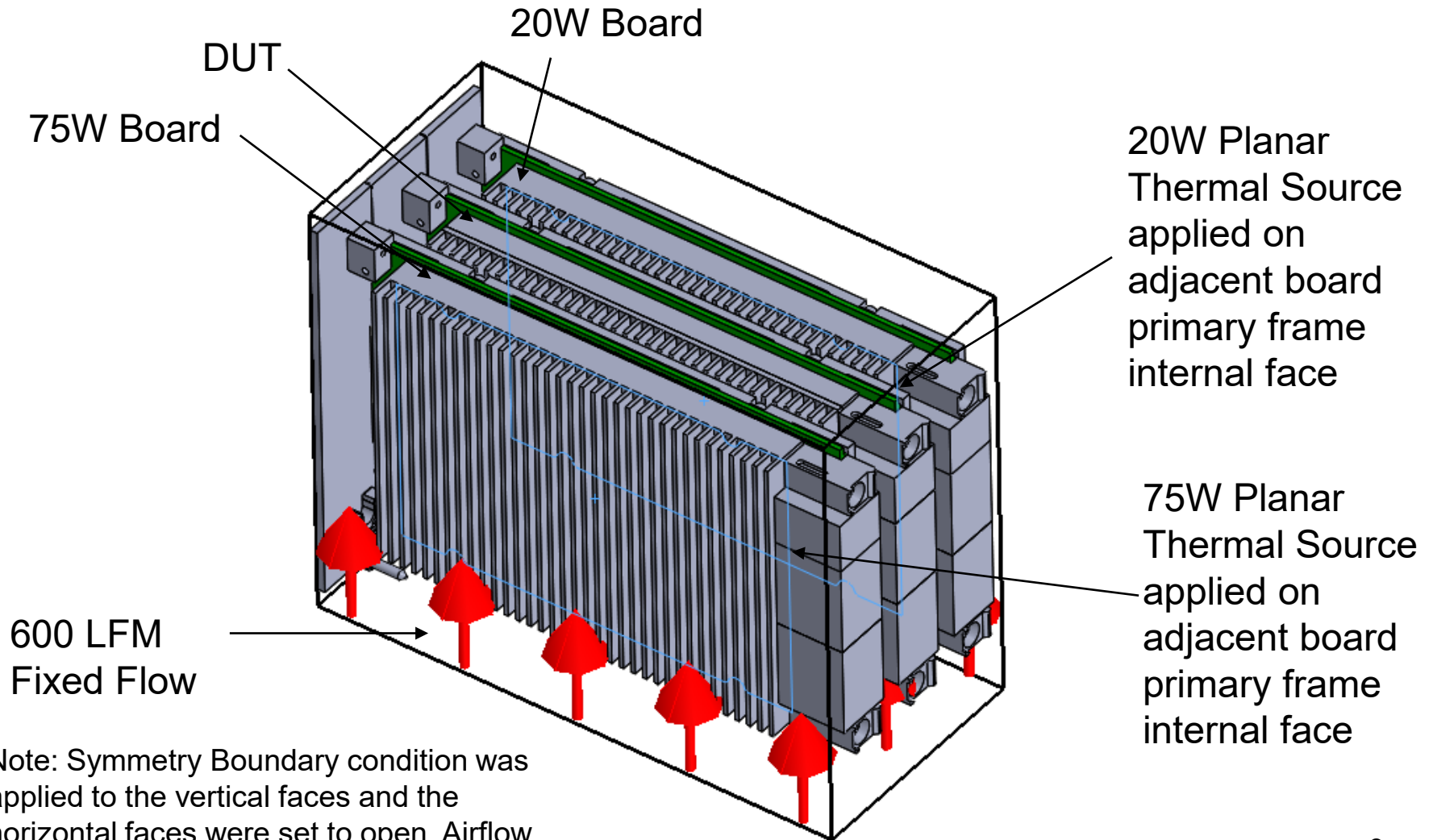

Note: Symmetry Boundary condition was applied to the vertical faces and the horizontal faces were set to open. Airflow direction is from the bottom to the top.

Thermal Model Setup –Overview: Adjacent Boards (continued)

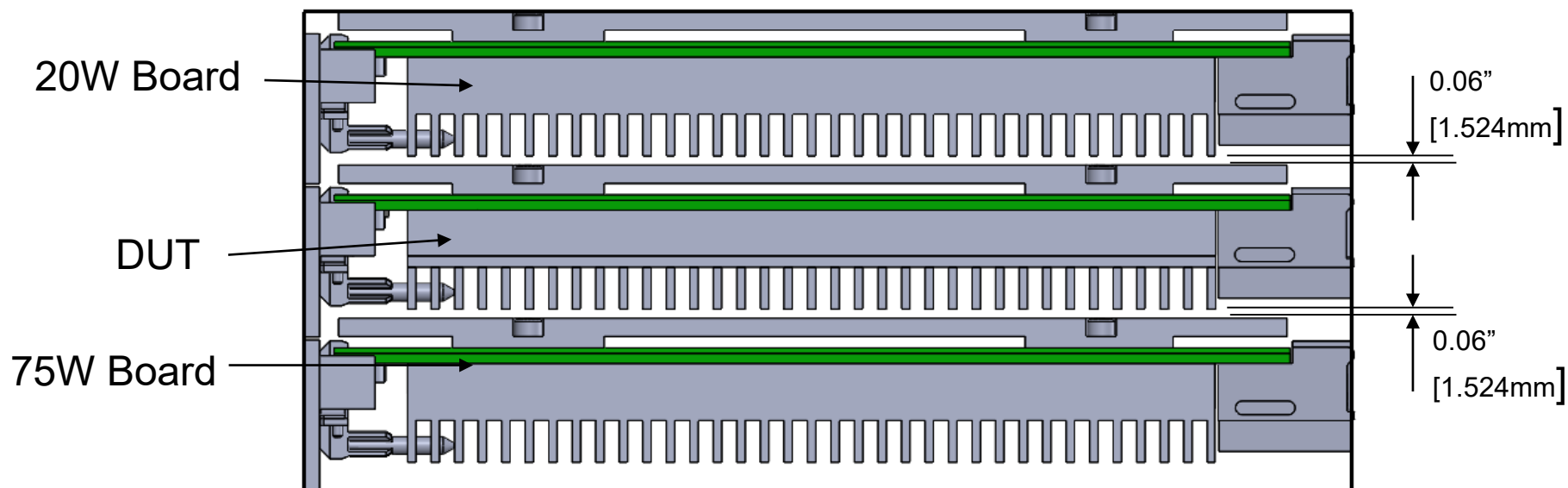

Thermal Data

CF-170300-233	Sandia Config. (W)			Thermal Resistance (°C/W)/Model		Maximum Temperature (°C)
Component [Ref. Des.]	Qty	Per Component	Total	R _{JC}	R _{JB}	
Aldrin [U1]	1	20.5	20.50	0.16	1.72	110 (junction)
CPU [U8]	1	4.67	4.67	2.57	6.89	115 (junction)
Quad PHY [U12A,U12B]	2	4.2	8.40	0.3	2.6	105 (junction)
0V88 / 1V0 Regulator [U4]	1	2.05	2.05	3.7	1.5	125 (junction)
1V0 Regulator [U6]	1	0.6	0.60	3.7	1.5	125 (junction)
1V8 Regulator [U15]	1	0.11	0.11	5	2	125 (junction)
1V5 Regulator [U26]	1	0.19	0.19	5	2	125 (junction)
Spread on the Board (Misc.)	1	1.41	1.41			
		Total	37.93			

CF-170300-233	10G Op.(W)			Thermal Resistance (°C/W)/Model		Maximum Temperature (°C)
Component [Ref. Des.]	Qty	Per Component	Total	R _{JC}	R _{JB}	
Aldrin [U1]	1	23.18	23.18	0.16	1.72	110 (junction)
CPU [U8]	1	4.67	4.67	2.57	6.89	115 (junction)
Quad PHY [U12A,U12B]	2	13.12	26.24	0.3	2.6	105 (junction)
0V88 / 1V0 Regulator [U4]	1	2.32	2.32	3.7	1.5	125 (junction)
1V0 Regulator [U6]	1	1.52	1.52	3.7	1.5	125 (junction)
1V8 Regulator [U15]	1	0.12	0.12	5	2	125 (junction)
1V5 Regulator [U26]	1	0.59	0.59	5	2	125 (junction)
Spread on the Board (Misc.)	1	2.48	2.48			
		Total	61.12			

Note: Thermal resistances from junction to case (R_{JC}) and from junction to board (R_{JB}) and thermal limits were taken from “Parts Thermal Characteristics.pdf”. Items in red were based on typical values for a similar package (15 Ld QFN).

Thermal Data (continued)

CF-170300-233	Worst-case Power (W)			Thermal Resistance (°C/W)/Model		Maximum Temperature (°C)
	Component [Ref. Des.]	Qty	Per Component	Total	R _{JC}	
Aldrin [U1]	1	43	43.00	0.16	1.72	110 (junction)
CPU [U8]	1	7.8	7.80	2.57	6.89	115 (junction)
Quad PHY [U12A,U12B]	2	13.5	27.00	0.3	2.6	105 (junction)
0V88 / 1V0 Regulator [U4]	1	4.3	4.30	3.7	1.5	125 (junction)
1V0 Regulator [U6]	1	1.74	1.74	3.7	1.5	125 (junction)
1V8 Regulator [U15]	1	0.22	0.22	5	2	125 (junction)
1V5 Regulator [U26]	1	0.61	0.61	5	2	125 (junction)
Spread on the Board (Misc.)	1	3.24	3.24			
		Total	87.91			

Note: Thermal resistances from junction to case (R_{JC}) and from junction to board (R_{JB}) and thermal limits were taken from “Parts Thermal Characteristics.pdf”. Items in red were based on typical values for a similar package (15 Ld QFN).

Thermal Analysis

Results Summary

Scenario					Thermal-027		Thermal-027		Thermal-027	
Parameters										
Ambient Temp., °C					-30		23		50	
Elevation, ft					10,000		0		0	
Approach Air Speed, LFM					600		600		600	
Remarks					Sandia Config		Sandia Config		Sandia Config	
RESULTS										
Component [Ref. Des]	Power, W	Min. Limit, °C	Max. Limit, °C	Limit Type	Result, °C	Margin, °C	Result, °C	Margin, °C	Result, °C	Margin, °C
Aldrin [U1]	20.5	-40	110	junction	-9.0	119.0	42.3	67.7	69.1	40.9
CPU [U8]	4.67	-	115	junction	-8.2	123.2	43.3	71.7	70.2	44.8
Quad PHY [U12A]	4.2	-	105	junction	-17.1	122.1	34.4	70.6	61.3	43.7
Quad PHY [U12B]	4.2	-	105	junction	-17.2	122.2	34.3	70.7	61.3	43.7
0V88 / 1V0 Regulator [U4]	2.05	-40	125	junction	-14.2	139.2	37.3	87.7	64.2	60.8
1V0 Regulator [U6]	0.6	-40	125	junction	-16.5	141.5	34.9	90.1	61.8	63.2
1V8 Regulator [U15]	0.11	-	125	junction	-18.1	143.1	33.4	91.6	60.3	64.7
1V5 Regulator [U26]	0.19	-	125	junction	-19.8	144.8	31.8	93.2	58.7	66.3
Pressure Drop, in. w.g.					0.407		0.484		0.455	

- For the Sandia Config. and 50°C, the Aldrin has a 41°C margin.

Results Summary (continued)

Scenario					Thermal-027		Thermal-027		Thermal-027	
Parameters										
Ambient Temp., °C					-30		23		50	
Elevation, ft					10,000		0		0	
Approach Air Speed, LFM					600		600		600	
Remarks					10G Op.		10G. Op		10G Op.	
RESULTS										
Component [Ref. Des]	Power, W	Min. Limit, °C	Max. Limit, °C	Limit Type	Result, °C	Margin, °C	Result, °C	Margin, °C	Result, °C	Margin, °C
Aldrin [U1]	23.18	-40	110	junction	-1.5	111.5	48.8	61.2	75.7	34.3
CPU [U8]	4.67	-	115	junction	-3.9	118.9	46.9	68.1	73.8	41.2
Quad PHY [U12A]	13.12	-	105	junction	-2.6	107.6	47.8	57.2	74.6	30.4
Quad PHY [U12B]	13.12	-	105	junction	-2.6	107.6	47.8	57.2	74.7	30.3
0V88 / 1V0 Regulator [U4]	2.32	-40	125	junction	-6.6	131.6	43.9	81.1	70.9	54.1
1V0 Regulator [U6]	1.52	-40	125	junction	-9.6	134.6	41.1	83.9	68.0	57.0
1V8 Regulator [U15]	0.12	-	125	junction	-12.3	137.3	38.4	86.6	65.3	59.7
1V5 Regulator [U26]	0.59	-	125	junction	-10.9	135.9	39.7	85.3	66.6	58.4
Pressure Drop, in. w.g.					0.408		0.485		0.456	

- For the 10G Op. Power. and 50°C, the Aldrin has a 34°C margin while the Quad PHY has 30°C margin.

Results Summary (continued)

Scenario					Thermal-027		Thermal-027		Thermal-027	
Parameters										
Ambient Temp., °C					-30		23		50	
Elevation, ft					10,000		0		0	
Approach Air Speed, LFM					600		600		600	
Remarks					Worst-Case Power		Worst-Case Power		Worst-Case Power	
RESULTS										
Component [Ref. Des]	Power, W	Min. Limit, °C	Max. Limit, °C	Limit Type	Result, °C	Margin, °C	Result, °C	Margin, °C	Result, °C	Margin, °C
Aldrin [U1]	43	-40	110	junction	16.2	93.8	65.2	44.8	92.0	18.0
CPU [U8]	7.8	-	115	junction	11.5	103.5	61.1	53.9	88.0	27.0
Quad PHY [U12A]	13.5	-	105	junction	4.0	101.0	53.4	51.6	80.1	24.9
Quad PHY [U12B]	13.5	-	105	junction	3.9	101.1	53.3	51.7	80.1	24.9
0V88 / 1V0 Regulator [U4]	4.3	-40	125	junction	5.9	119.1	55.3	69.7	82.2	42.8
1V0 Regulator [U6]	1.74	-40	125	junction	0.2	124.8	49.7	75.3	76.5	48.5
1V8 Regulator [U15]	0.22	-	125	junction	-3.6	128.6	46.1	78.9	72.9	52.1
1V5 Regulator [U26]	0.61	-	125	junction	-4.8	129.8	44.9	80.1	71.7	53.3
Pressure Drop, in. w.g.					0.409		0.486		0.457	

- For the Worst-Case Power. and 50°C, the Aldrin has a 18°C margin while the Quad PHY has 25°C margin.

Board Surface Temperature Plot

Worst-Case Power, 50°C , sea level

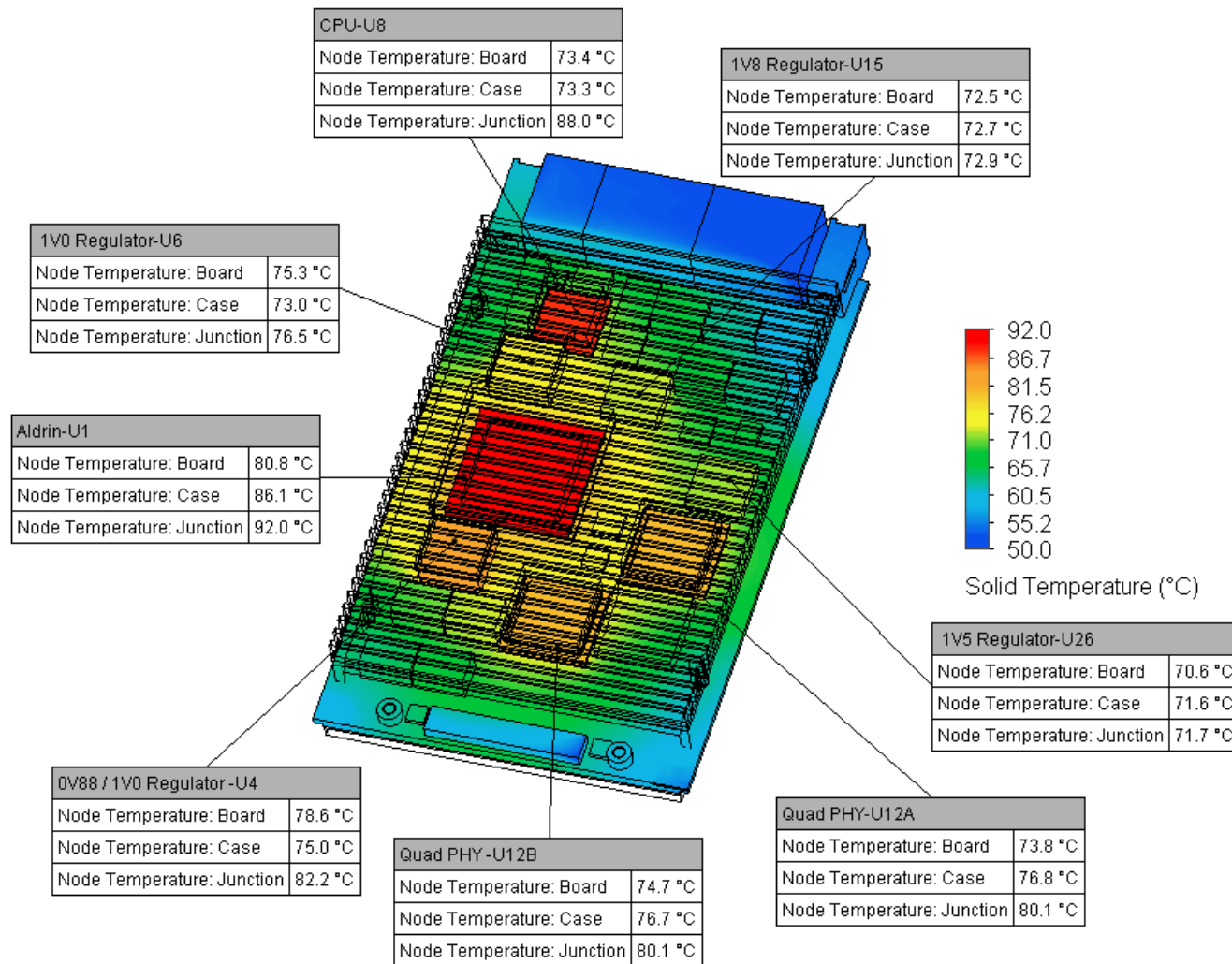

Heatsink/Frame Surface Temperature Plot

Worst-Case Power, 50°C , sea level

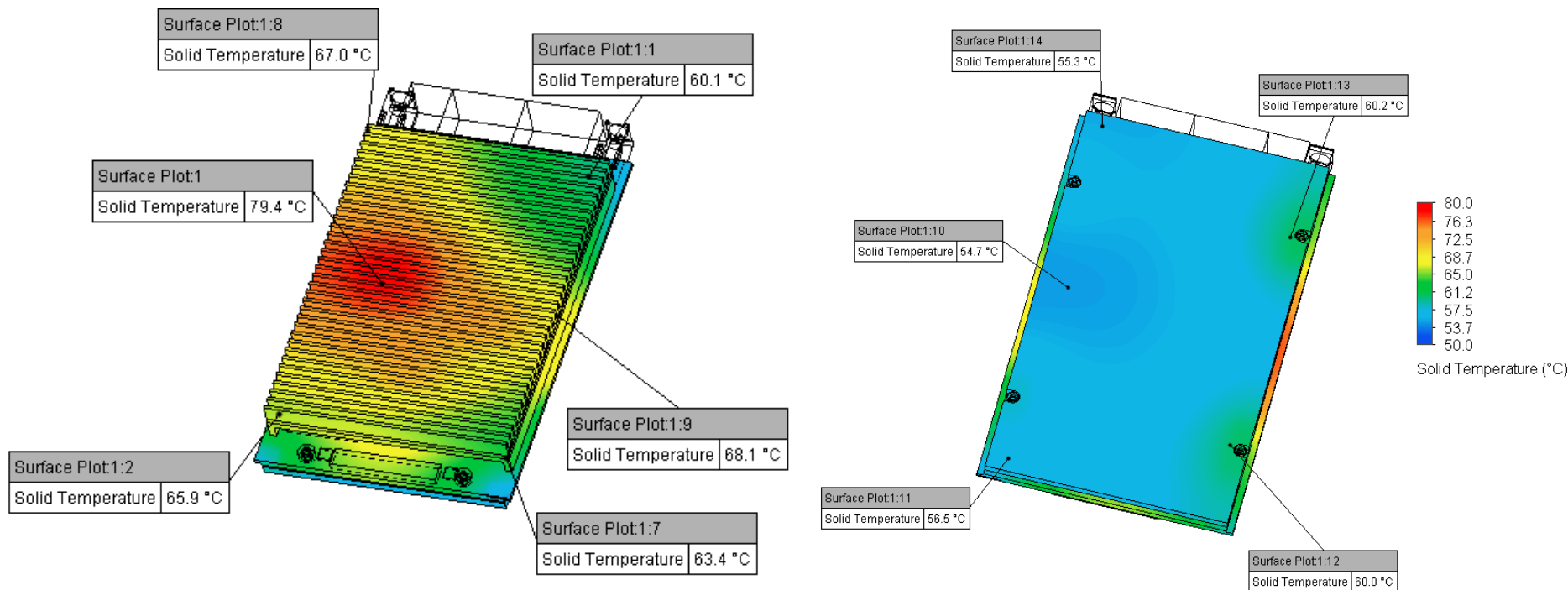

- The primary frame/heatsink is the main cooling solution with a hotspot of 80°C above the Aldrin.

Cutplane Temperature Plot: Mid-height of DUT Primary Frame Fins

Worst-Case Power, 50°C , sea level

CUTPLANE
LOCATION:

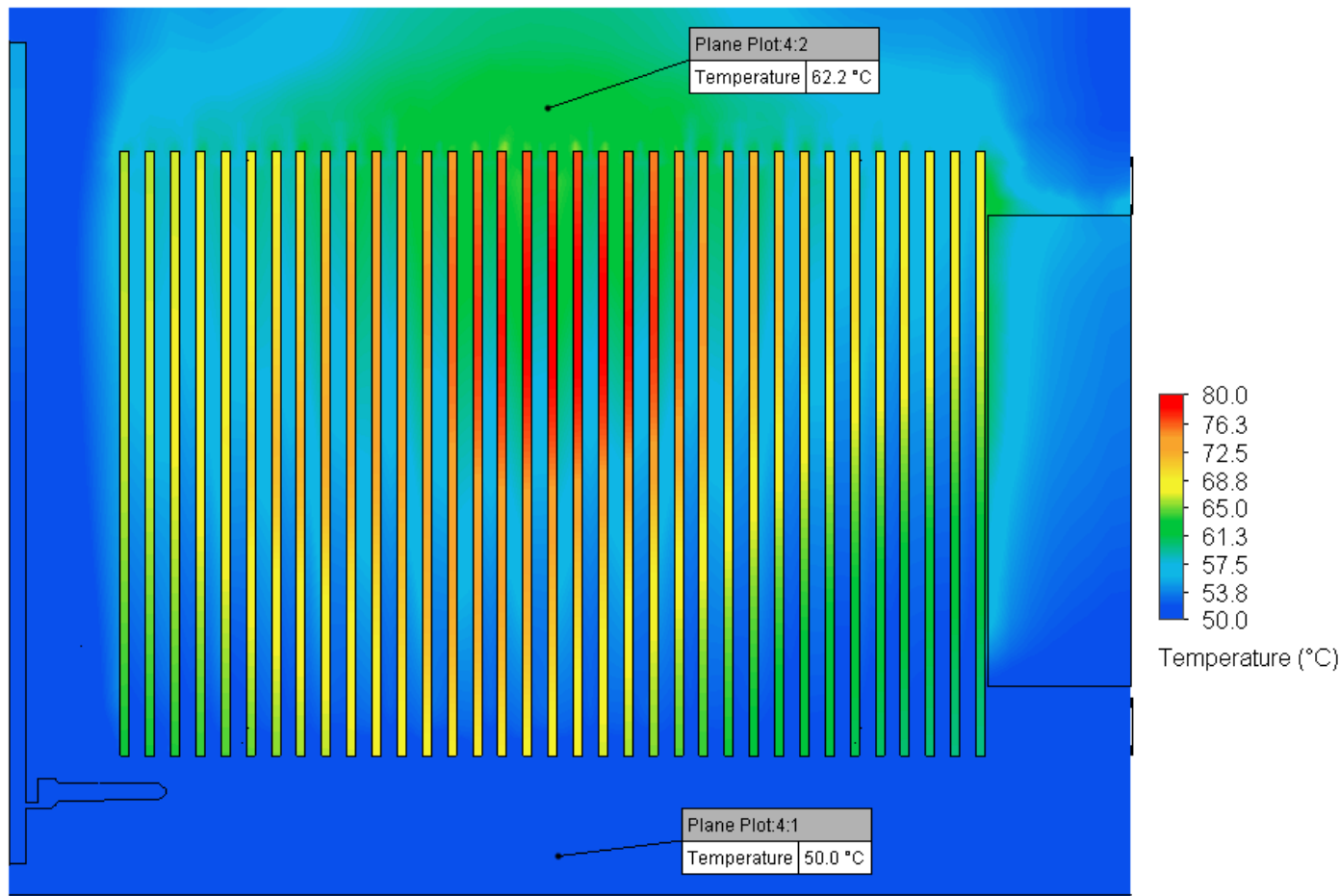

- Note that the air temperature increases around 10°C through the fins of the primary frame.

Cutplane Speed Plot: Mid-height of DUT Primary Frame Fins Worst-Case Power, 50°C , sea level

CUTPLANE
LOCATION:

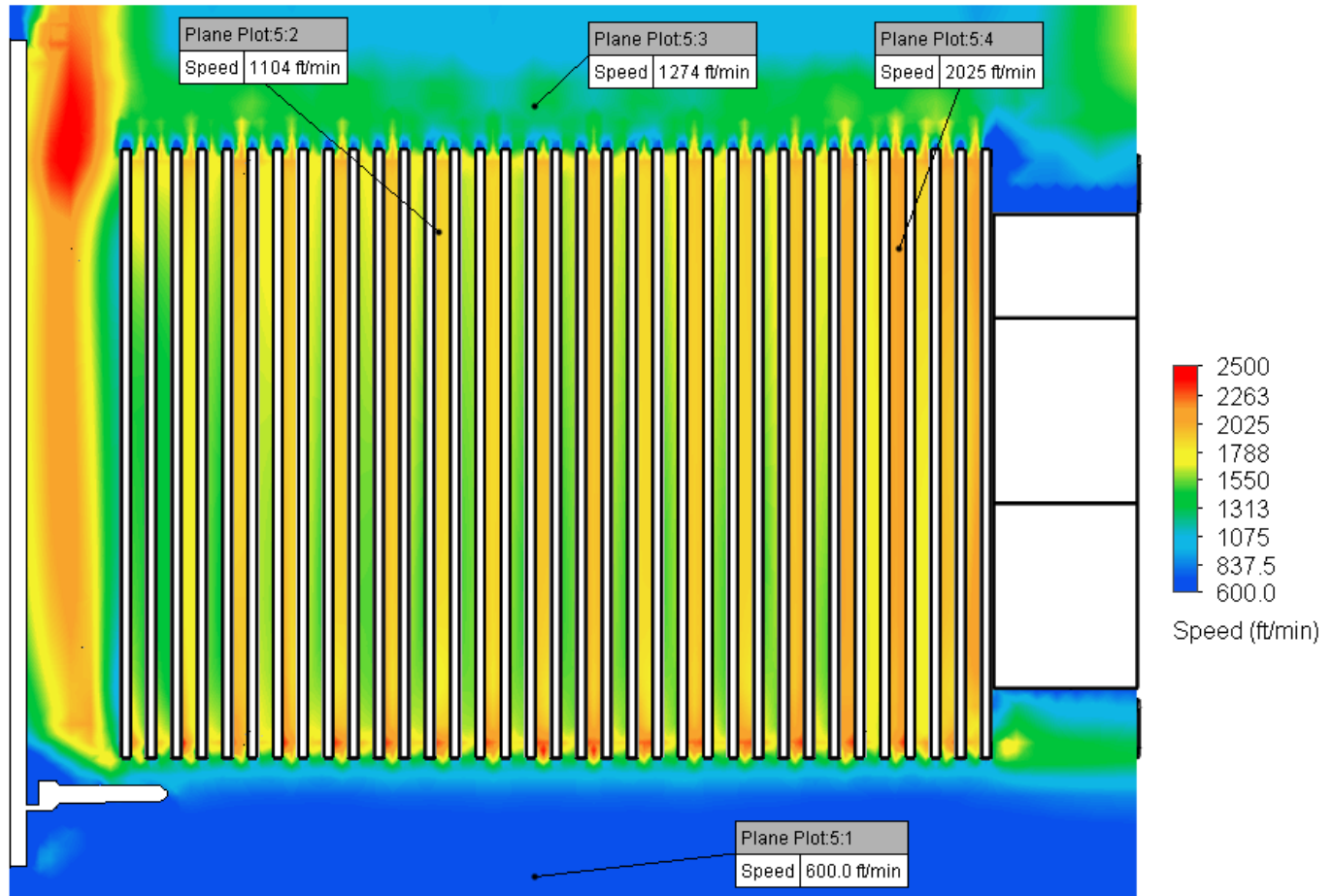

- The air speed between the fins reaches up to 2000 LFM due to the cross section reduction in the slot, thus the air is funneled between the fins.

Cutplane Pressure Plot: Mid-height of DUT Primary Frame Fins Worst-Case Power, 50°C , sea level

CUTPLANE
LOCATION:

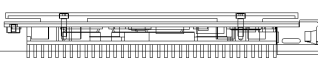

**Pressure Drop:
0.46 inH₂O**

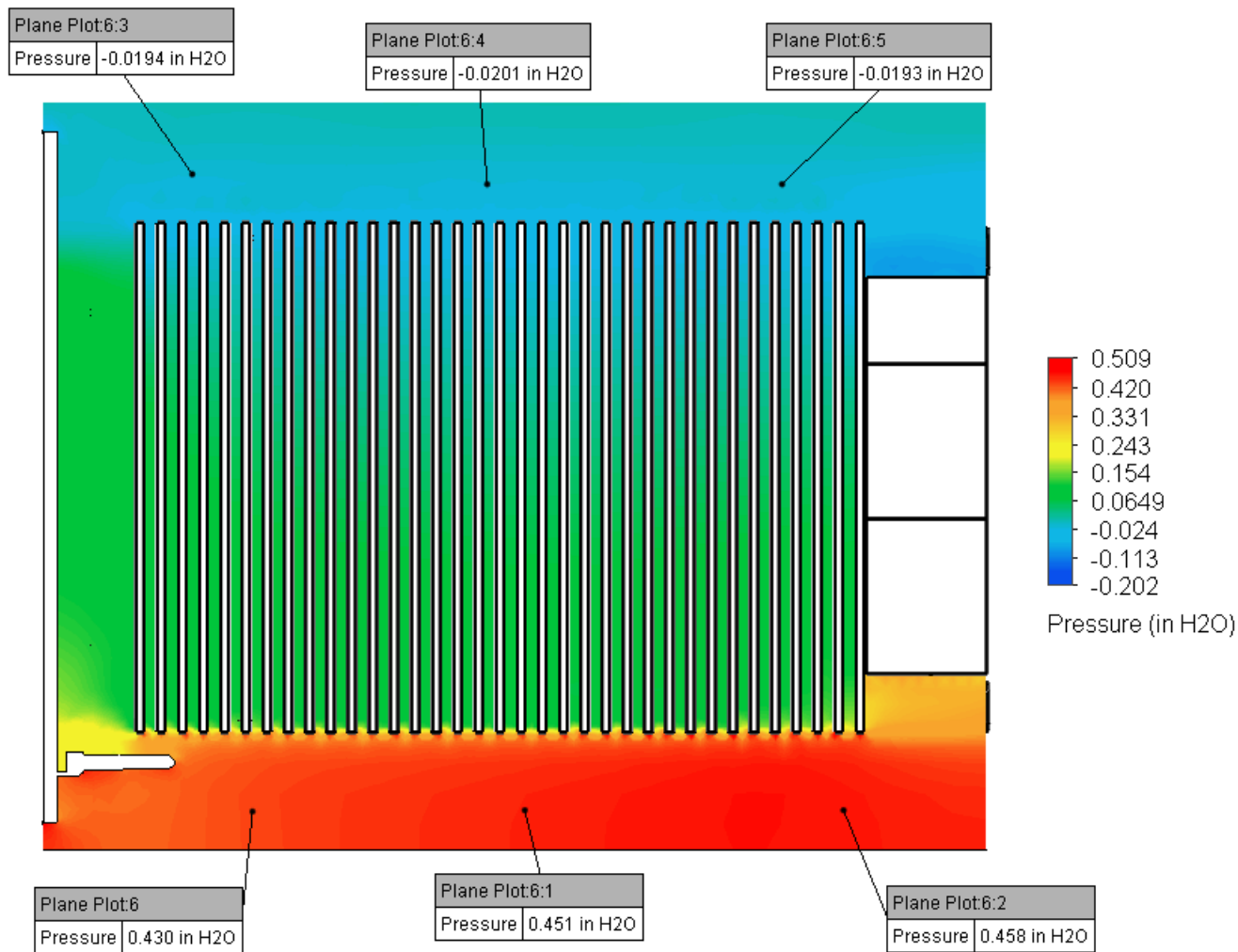

Board Surface Temperature Plot

10G Op. Power, 50°C , sea level

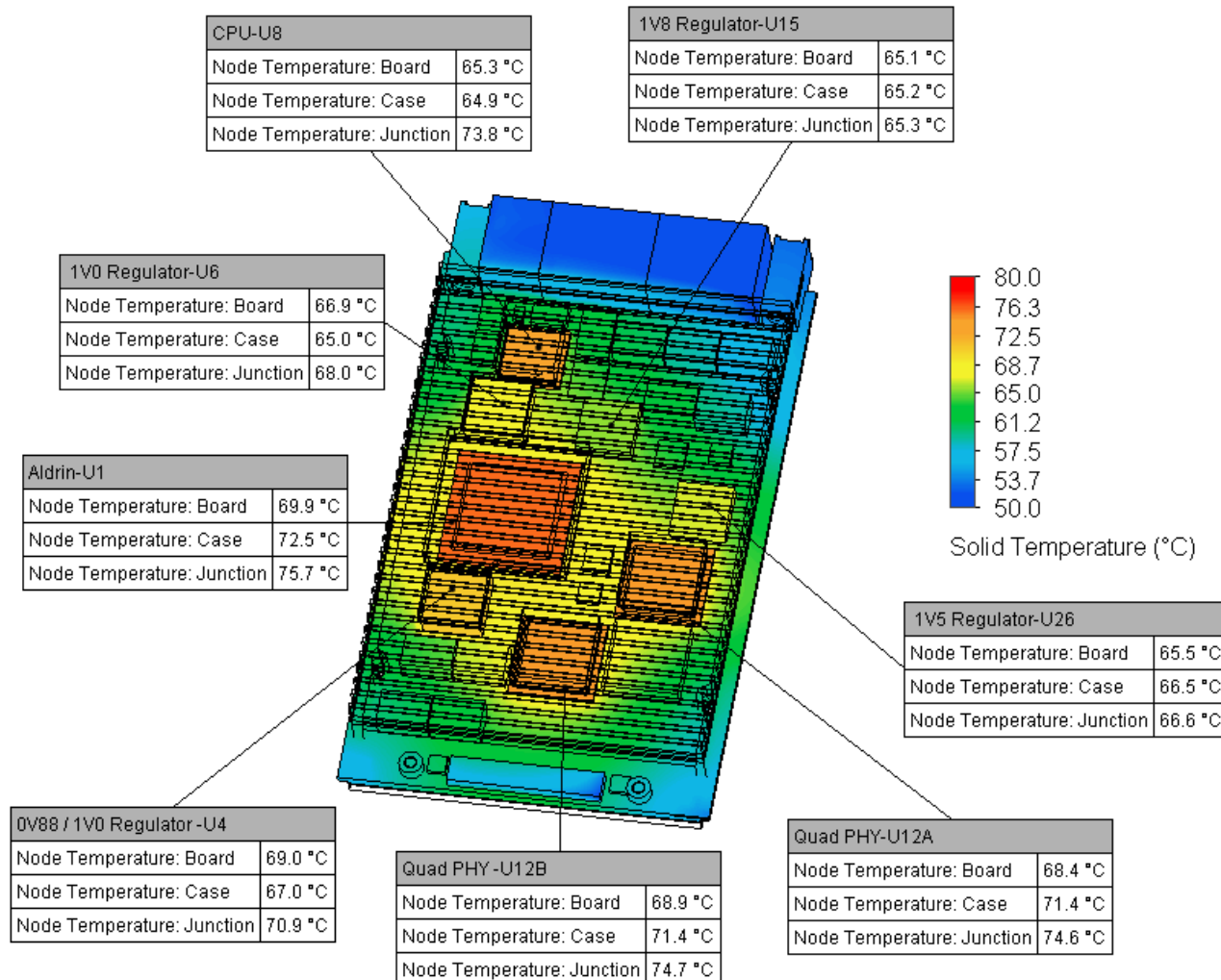

What-if Scenario with Approach Air Speed at 300 LFM for Worst-Case Power at 50°C

Scenario					Thermal-027		Thermal-027	
Parameters								
Ambient Temp., °C					50		50	
Elevation, ft					0		0	
Approach Air Speed, LFM					600		300	
Remarks					Worst-Case Power		Worst-Case Power	
RESULTS								
Component [Ref. Des]	Power, W	Min. Limit, °C	Max. Limit, °C	Limit Type	Result, °C	Margin, °C	Result, °C	Margin, °C
Aldrin [U1]	43	-40	110	junction	92.0	18.0	99.7	10.3
CPU [U8]	7.8	-	115	junction	88.0	27.0	95.1	19.9
Quad PHY [U12A]	13.5	-	105	junction	80.1	24.9	86.9	18.1
Quad PHY [U12B]	13.5	-	105	junction	80.1	24.9	87.2	17.8
0V88 / 1V0 Regulator [U4]	4.3	-40	125	junction	82.2	42.8	89.6	35.4
1V0 Regulator [U6]	1.74	-40	125	junction	76.5	48.5	83.8	41.2
1V8 Regulator [U15]	0.22	-	125	junction	72.9	52.1	79.4	45.6
1V5 Regulator [U26]	0.61	-	125	junction	71.7	53.3	78.1	46.9
Pressure Drop, in. w.g.					0.457		0.137	

Motivation for this scenario is that the cross section reduction causes high air velocity between the fins; this might be not realistic.

- For the Worst-Case Power. and 50°C and with half the approach air speed at 300 LFM, the Aldrin has a 10°C margin while the Quad PHY has 18°C margin.

Flow Resistance of Board and Frame at 23°C, sea level

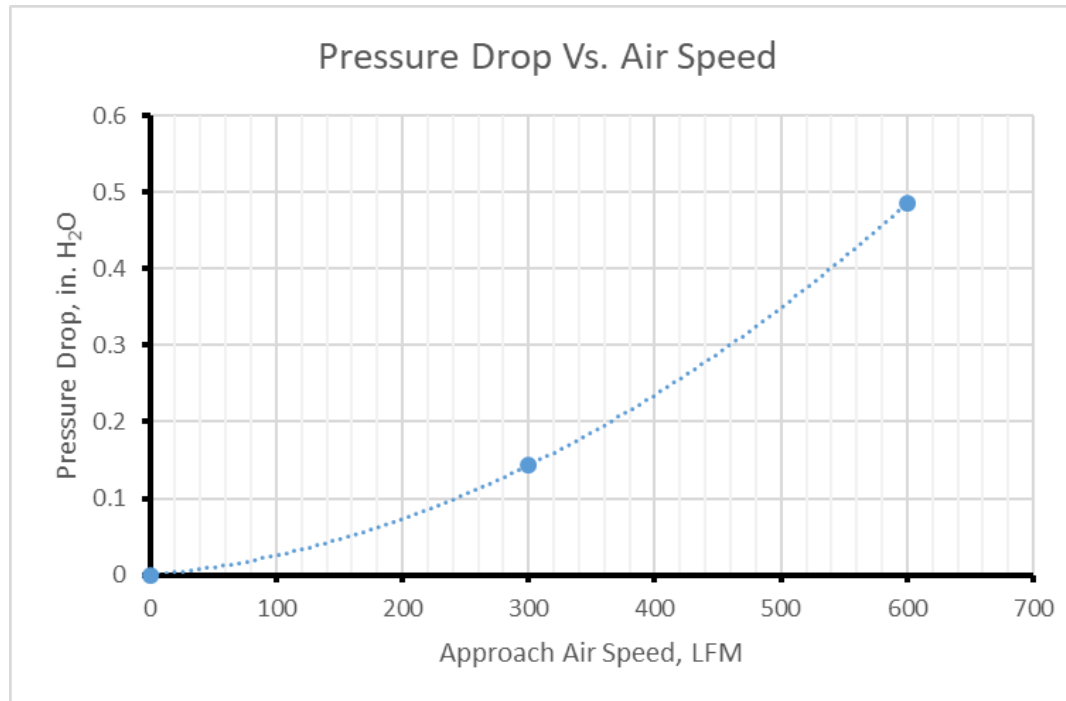

- Pressure Drop (in H₂O)= $1.11111\text{E-}06 \cdot (\text{LFM})^2 + 1.43333\text{E-}04 \cdot (\text{LFM})$

Recommendations

- Results show that the critical components are within their thermal limits even for the worst-case power at the highest specified ambient temperature (50°C) environment.
 - Assuming the approach air speed is correct, the Aldrin will still have an 8°C margin in a 60°C, sea level environment with worst-case power and will be the only component with a single-digit margin.
- It is recommended to check if there is a pressure drop limit associated with the 600 LFM approach airflow. At worst-case power and at 50°C, the critical components still have margins of at least 10°C at a lower approach air speed (300 LFM) and would have significantly reduced pressure drop (0.137 in. H₂O vs 0.457 in. H₂O at 600 LFM).
- The fin spacing is close to optimal. It is recommended to keep the current design.